

SIC type

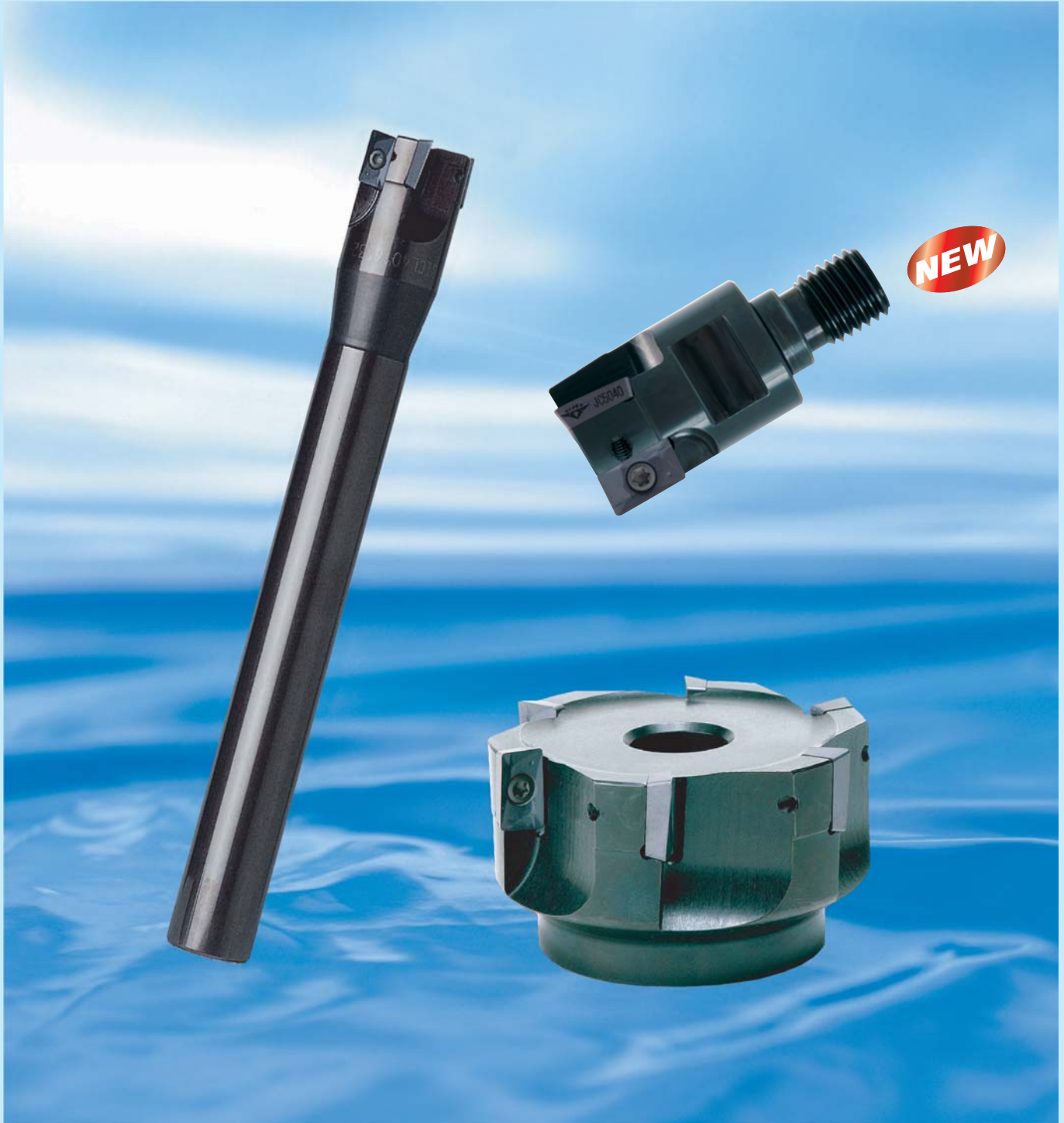

“ Side Chipper ”



“ MIC Side Chipper Heads ”



“ Side Chipper ”



■ SIC type

INDEXABLE END MILL

■ Features

1. Super End-Chipper inserts can be used Side-Chipper bodies.
2. 3D inserts geometry gives low cutting forces and excellent chip ejection for high productivity.

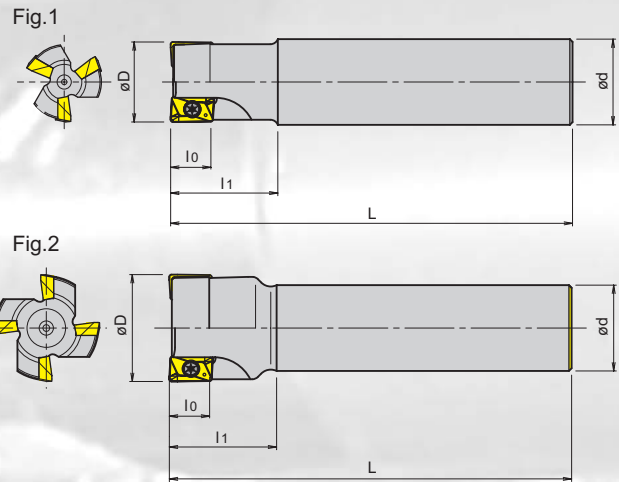
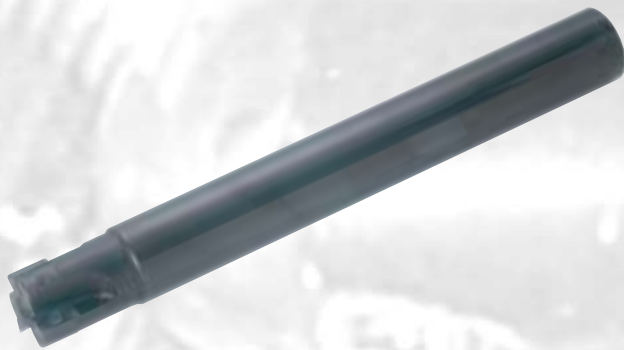

■ Body (Standard Type)

Cat. No.	Stock	No. of inserts	Dimensions (mm)					Inserts	Fig.
			øD	l ₀	l ₁	L	ød		
SICM1610S16-2N	●	2	16	10	25	100	16	ZCMT100308R	1
SICM2010S20-3N	●	3	20	10	25	110	20	ZCMT100308R	1
SICM2510S25-4N	●	4	25	10	32	120	25	ZCMT100308R	1
SICM2513S25-3N	●	3		13				ZPMT13T3..R	1
SICM3016S32-3N	●	3	30	15	40	150	32	ZPMT1604..R	1
SICM3210S32-5N	●	5	32	10	40	150	32	ZCMT100308R	1
SICM3216S32-3N	●	3		15				ZPMT1604..R	1
SICM4010S32-6N	●	6	40	10	40	150	32	ZCMT100308R	2
SICM4016S32-4N	●	4		15				ZPMT1604..R	2
SICM5010S32-7N	●	7	50	10	40	150	32	ZCMT100308R	2
SICM5016S32-5N	●	5		15				ZPMT1604..R	2

● Stock in Japan

■ Body (Long Type)

Cat. No.	Stock	No. of inserts	Dimensions (mm)					Inserts	Fig.
			øD	l ₀	l ₁	L	ød		
SICL1610S16-2N	●	2	16	10	25	150	16	ZCMT100308R	1
SICL2010S20-2N	●	2	20	10	40	180	20	ZCMT100308R	1
SICL2010S20-3N	●	3						ZCMT100308R	1
SICL2513S25-2N	●	2	25	13	35	210	25	ZPMT13T3..R	1
SICL2513S25-3N	●	3						ZPMT13T3..R	1
SICL3016S25-3N	●	3	30	15	65	250	25	ZPMT1604..R	2
SICL3216S32-2N	●	2	32	15	65	250	32	ZCMT100308R	1
SICL3216S32-3N	●	3						ZPMT1604..R	1
SICL4016S32-4N	●	4	40	15	65	250	32	ZPMT1604..R	2
SICL5016S42-5N	●	5	50	15	65	250	42	ZPMT1604..R	2

■ Attention to use 3.0 or 3.2 mm Corner Radius

Body must be modified to 1.5 mm. Radius or 1.2 mm Chamfer at corner.

● Stock in Japan

“ Side Chipper ”



■ SIC (Face Mill Type)

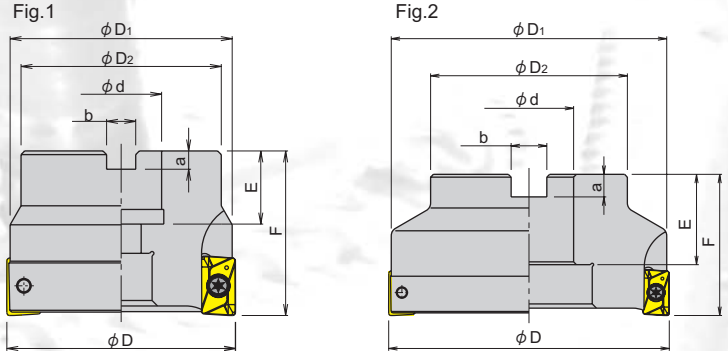
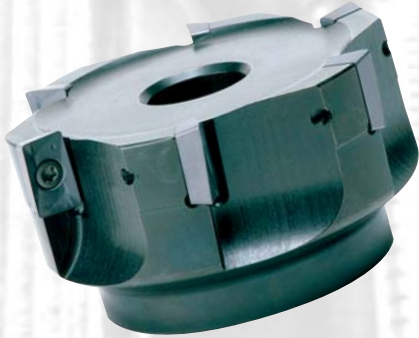

■ Body

Cat.No.	Stock	No. Inserts	Dimensions (mm)								Insert	Fig.
			ϕD	ϕD_1	ϕD_2	F	ϕd	a	b	E		
SIC-4050R-22	●	4	50	48.2	45	45	22	6.3	10.4	20	ZPMT1604 . . R	1
SIC-5063R-22	●	5	63	61	55	45	22	6.3	10.4	20		1
SIC-6080R-27	●	6	80	78	60	50	27	7	12.4	22		2
SIC-8100R-32	●	8	100	98	70	50	32	8	14.4	32		2
NEW SIC-8125R-40	●	8	125	123	85	63	40	9	16.4	35		2

■ MIC SIC Heads Type (with trough coolant hole)

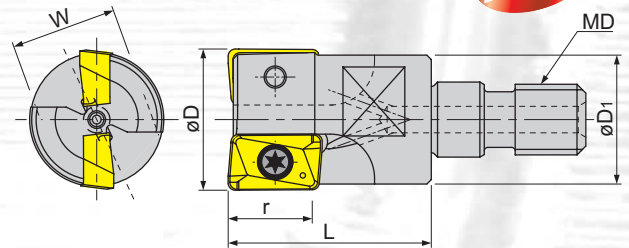
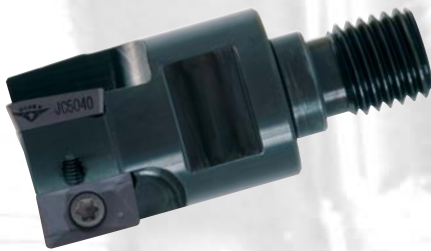

■ Body

Cat. No.	Stock	No. of inserts	Dimensions (mm)						Applicable inserts	Parts	
			ϕD	r	L	ϕD_1	MD	W		Clamp screw	Wrench
MIC-2016-M8	●	2	16	9	23	14.6	M8	12	ZCMT100308R	ESW-206	A-08SD
MIC-2018-M8	●	2	18	9	23	15.5	M8	12			
MIC-3020-M10	●	3	20	9	30	18.4	M10	14	ZCMT100308R	ESW-206	A-08SD
MIC-2022-M10	●	2	22	12.5	30	19.5	M10	14	ZPMT13T3OOR	DSW-307	A-10SD
MIC-3022-M10	●	3	22	9	30	19.5	M10	14	ZCMT100308R	ESW-206	A-08SD
MIC-3025-M12	●	3	25	12.5	35	23	M12	17	ZPMT13T3OOR	DSW-307	A-10SD
MIC-2027-M12	●	2	27	15	35	24	M12	17	ZPMT1604OOR	TSW-408	A-15SD
MIC-3027-M12	●	3	27	12.5	35	24	M12	17	ZPMT13T3OOR	DSW-307	A-10SD
MIC-3030-M16	●	3	30	15	43	28.2	M16	22	ZPMT1604OOR	TSW-408	A-15SD
MIC-2032-M16	●	2	32	15	43	29	M16	22			
MIC-3032-M16	●	3	32	15	43	29	M16	22			
MIC-4040-M16	●	4	40	15	43	29	M16	22	ZPMT13T3OOR	DSW-307	A-10SD
MIC-5040-M16	●	5	40	12.5	43	29	M16	22			

■ Attention to use 3.0 or 3.2 mm Corner Radius

Body must be modified to 1.5 mm. Radius or 1.2 mm Chamfer at corner.

Note : Please see page 117~124 for cutting conditions.

“ Side Chipper ”



MMT Morse Taper type

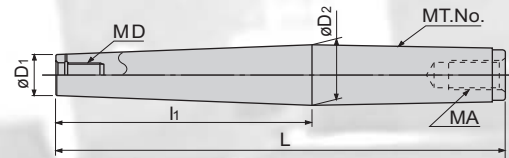

Body

Cat. No.	Stock	Dimensions (mm)							Applicable head
		øD ₁	øD ₂	l ₁	L	MD	MT. No.	MA	
MMT-M8-50-MT2	○	15	18.030	50	119	M8	MT2	M10	MIC-2016-M8, MIC-2018-M8
MMT-M8-80-MT3	○		24.076	80	166		MT3	M12	
MMT-M8-110-MT3	○		24.076	110	196		MT3	M12	
MMT-M10-60-MT3	○	19	24.076	60	146	M10	MT3	M12	MIC-3020-M10, MIC-2022-M10 MIC-3022-M10
MMT-M10-80-MT3	○		24.076	80	166		MT3	M12	
MMT-M10-110-MT4	○		31.605	110	219		MT4	M16	
MMT-M12-50-MT3	○	21	24.076	50	136	M12	MT3	M12	MIC-3025-M12, MIC-2027-M12 MIC-3027-M12
MMT-M12-80-MT3	○		24.076	80	166		MT3	M12	
MMT-M12-110-MT4	○		31.605	110	219		MT4	M16	
MMT-M12-140-MT4	○		31.605	140	249		MT4	M16	
MMT-M16-50-MT4	○	29	31.605	50	159	M16	MT4	M16	MIC-3030-M16, MIC-2032-M16 MIC-3032-M16, MIC-4040-M16 MIC-5040-M16
MMT-M16-80-MT4	○		31.605	80	189		MT4	M16	
MMT-M16-110-MT5	○		44.741	110	246		MT5	M20	
MMT-M16-140-MT5	○		44.741	140	276		MT5	M20	
MMT-M16-180-MT5	○		44.741	180	316		MT5	M20	

○ Will not be available after current stock exhausted.

MSN Straight Neck type (Through Coolant Hole)

- For high productivity
- High rigidity

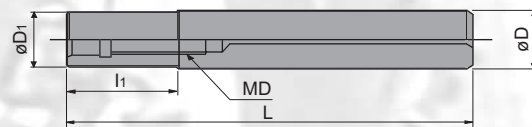

Body

Cat. No.	Stock	Dimensions (mm)					Applicable head
		øD	l ₁	L	øD ₁	MD	
NEW MSN-M8-40-S16C	●	16	40	95	15.5	M8	MIC-2016-M8, MIC-2018-M8
NEW MSN-M8-80-S16C	●		80	135			
NEW MSN-M8-120-S16C	●		120	175			
MSN-M10-40-S20C	●	20	40	100	19.5	M10	MIC-3020-M10, MIC-2022-M10 MIC-3022-M10
MSN-M10-90-S20C	●		90	150			
MSN-M10-140-S20C	●		140	200			
MSN-M12-55-S25C	●	25	55	120	24	M12	MIC-3025-M12, MIC-2027-M12 MIC-3027-M12
MSN-M12-105-S25C	●		105	170			
MSN-M12-155-S25C	●		155	220			
MSN-M16-55-S32C	●	32	55	120	29	M16	MIC-3030-M16, MIC-2032-M16 MIC-3032-M16, MIC-4040-M16 MIC-5040-M16
MSN-M16-105-S32C	●		105	170			
MSN-M16-155-S32C	●		155	220			

“ Side Chipper ”



■ MSN Straight Arbor Type (Through Coolant Hole)

- For high productivity
- High rigidity

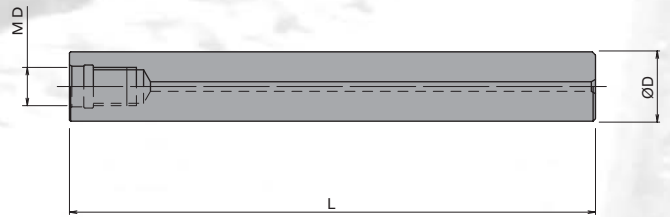

■ Body

Cat. No.	Stock	Dimensions (mm)			Applicable holders
		ØD	L	MD	
MSN-M10-130S-S18C	●	18	130	M10	MIC-3020-M10 MIC-2022-M10 MIC-3022-M10
MSN-M10-190S-S18C	●		190		
MSN-M10-130S-S20C	●	20	130		
MSN-M10-190S-S20C	●		190		
MSN-M10-250S-S20C	●		250		
MSN-M12-185S-S23C	●	23	185		
MSN-M12-265S-S23C	●		265		
MSN-M12-145S-S25C	●	25	145		
MSN-M12-215S-S25C	●		215		
MSN-M12-285S-S25C	●		285		
MSN-M16-160S-S28C	●	28	160	M16	MIC-3030-M16 MIC-2032-M16 MIC-3032-M16 MIC-4040-M16 MIC-5040-M16
MSN-M16-230S-S28C	●		230		
MSN-M16-310S-S28C	●	32	310		
MSN-M16-157S-S32C	●		157		
MSN-M16-217S-S32C	●		217		
MSN-M16-287S-S32C	●	375	287		
MSN-M16-357S-S32C	●		375		

Note : Please see page 117~124 for cutting conditions.

■ Recommended tightening torque for modular head

Tread Size	Tightening Torque	Wrench Size mm.
M8	23 Nm	10,12
M10	46 Nm	14,15
M12	80 Nm	17
M16	90 Nm	22,26

Attention to mounting head !

Clean the contact surface of head and carbide holder, and also confirm there is no gap between head and holder after tightening.
Please check and try to obtain good run-out.

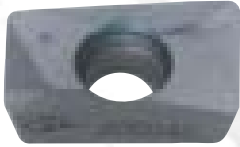

“ Side Chipper ”

■ SIC Inserts and parts

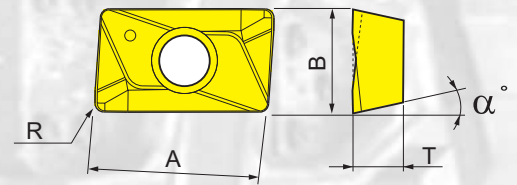

Alu-polished Insert



Cat. No.	Coated		Uncoated	Dimensions (mm)					Parts	
	JC5015	JC5040	FZ15	A	B	T	α°	R	Clamp screw	Wrench
										
ZCMT100308R/P	●	●	□	10.4	6.35	3.4	7	0.8	ESW-206 (0.9 N-m)	A-08SD
ZPMT13T308R/P	●	●	□	13.3	7.938	3.97	11	0.8	DSW-307 (1.4 N-m)	A-10SD
NEW ZPMT13T316R/P	●	●	□	13.3	7.938	3.97	11	1.6	DSW-307 (1.4 N-m)	A-10SD
ZPMT13T320R/P	●	●	□	13.3	7.938	3.97	11	2.0	DSW-307 (1.4 N-m)	A-10SD
ZPMT160408R/P	●	●	□	16	9.525	4.76	11	0.8	TSW-408 (3.1 N-m)	A-15SD
NEW ZPMT160416R/P	●	●	□	16	9.525	4.76	11	1.6	TSW-408 (3.1 N-m)	A-15SD
ZPMT160420R/P	●	●	□	16	9.525	4.76	11	2.0	TSW-408 (3.1 N-m)	A-15SD
ZPMT160430R/P	●	●	□	16	9.525	4.76	11	3.0	TSW-408 (3.1 N-m)	A-15SD
NEW ZPMT160432R/P	●	●	□	16	9.525	4.76	11	3.2	TSW-408 (3.1 N-m)	A-15SD

□ FZ15 Polished inserts for aluminium, please add **P** at the end of Cat. No.

□ Stock in Japan

“ Side Chipper ”

■ Recommended cutting conditions for SICM_ _10 insert's type - Shoulder cutting

Materials	Parameter	ø16	ø20	ø25	ø32	ø40	ø50
Carbon steel (C50, C55) 150-280HB	N (min ⁻¹)	2,990	2,390	1,910	1,500	1,200	960
	Vf (mm/min)	720	860	920	900	870	810
	Ap (mm)	3	3	3	3	3	3
	Ae (mm)	5	6	8	10	12	15
Alloy steel (1.7225) 150-280HB	N (min ⁻¹)	2,990	2,390	1,910	1,500	1,200	960
	Vf (mm/min)	600	720	770	750	720	680
	Ap (mm)	3	3	3	3	3	3
	Ae (mm)	5	6	8	10	12	15
Mold steel (1.2311,P20) 280-400HB	N (min ⁻¹)	2,390	1,910	1,530	1,200	960	770
	Vf (mm/min)	480	580	620	600	580	540
	Ap (mm)	2	2	2	2	2	2
	Ae (mm)	5	6	8	10	12	15
Tool & die steel (1.2344,1.2379) 150-255HB	N (min ⁻¹)	2,390	1,910	1,530	1,200	960	770
	Vf (mm/min)	480	580	620	600	580	540
	Ap (mm)	2	2	2	2	2	2
	Ae (mm)	5	6	8	10	12	15
Stainless steel (1.4301,1.4401) 150-250HB	N (min ⁻¹)	2,190	1,750	1,400	1,100	880	700
	Vf (mm/min)	440	530	560	550	530	490
	Ap (mm)	2	2	2	2	2	2
	Ae (mm)	5	6	8	10	12	15
Cast iron (GG25,GG30) 160-260HB	N (min ⁻¹)	3,190	2,250	2,040	1,600	1,280	1,020
	Vf (mm/min)	900	1,070	1,140	1,120	1,080	1,000
	Ap (mm)	3	3	3	3	3	3
	Ae (mm)	5	6	8	10	12	15
Nodular cast iron (GGG60,GGG70) 170-300HB	N (min ⁻¹)	2,990	2,390	1,910	1,500	1,200	960
	Vf (mm/min)	720	860	920	900	870	810
	Ap (mm)	3	3	3	3	3	3
	Ae (mm)	5	6	8	10	12	15

Note: 1. N: Spindle speed (min-1), Vf: Feed speed (mm/min)
 2. The figures to be adjusted according to the machine rigidity or work rigidity.
 3. Apply 40-60 % above depth of cut and feed rate to long type tools.

“ Side Chipper ”

■ Recommended cutting conditions for SICM_ _10 insert's type - Slotting

Materials	Parameter	ø16	ø20	ø25	ø32	ø40	ø50
Carbon steel (C50, C55) 150-280HB	N (min ⁻¹)	2,790	2,230	1,790	1,400	1,120	900
	Vf (mm/min)	560	670	720	700	680	630
	Ap (mm)	Up to 3	Up to 3	Up to 3	Up to 3	Up to 3	Up to 3
Alloy steel (1.7225) 150-280HB	N (min ⁻¹)	2,790	2,230	1,790	1,400	1,120	900
	Vf (mm/min)	450	540	580	560	540	510
	Ap (mm)	Up to 3	Up to 3	Up to 3	Up to 3	Up to 3	Up to 3
Mold steel (1.2311,P20) 280-400HB	N (min ⁻¹)	2,190	1,750	1,400	1,100	880	700
	Vf (mm/min)	350	420	450	440	430	400
	Ap (mm)	Up to 2	Up to 2	Up to 2	Up to 2	Up to 2	Up to 2
Tool & die steel (1.2344,1.2379) 150-255HB	N (min ⁻¹)	2,190	1,750	1,400	1,100	880	700
	Vf (mm/min)	350	420	450	440	430	400
	Ap (mm)	Up to 2	Up to 2	Up to 2	Up to 2	Up to 2	Up to 2
Stainless steel (1.4301,1.4401) 150-250HB	N (min ⁻¹)	1,990	1,600	1,280	1,000	800	640
	Vf (mm/min)	320	390	410	400	390	360
	Ap (mm)	Up to 2	Up to 2	Up to 2	Up to 2	Up to 2	Up to 2
Cast iron (GG25,GG30) 160-260HB	N (min ⁻¹)	2,990	2,390	1,910	1,500	1,200	960
	Vf (mm/min)	720	860	920	900	860	810
	Ap (mm)	Up to 3	Up to 3	Up to 3	Up to 3	Up to 3	Up to 3
Nodular cast iron (GGG60,GGG70) 170-300HB	N (min ⁻¹)	2,790	2,230	1,790	1,400	1,120	900
	Vf (mm/min)	560	670	720	700	680	630
	Ap (mm)	Up to 3	Up to 3	Up to 3	Up to 3	Up to 3	Up to 3

Note: 1. N: Spindle speed (min-1), Vf: Feed speed (mm/min)
 2. The figures to be adjusted according to the machine rigidity or work rigidity.
 3. Apply 40-60 % above depth of cut and feed rate to long type tools.

“ Side Chipper ”

■ Recommended cutting conditions for SICM_16 insert's type - Shoulder cutting

Materials	Parameter	ø30	ø32	ø40	ø50
Carbon steel (C50, C55) 150-280HB	N (min ⁻¹)	1,600	1,500	1,200	960
	Vf (mm/min)	870	810	870	870
	Ap (mm)	5	5	5	5
	Ae (mm)	9	10	12	15
Alloy steel (1.7225) 150-280HB	N (min ⁻¹)	1,600	1,500	1,200	960
	Vf (mm/min)	720	680	720	720
	Ap (mm)	5	5	5	5
	Ae (mm)	9	10	12	15
Mold steel (1.2311,P20) 280-400HB	N (min ⁻¹)	1,280	1,200	960	770
	Vf (mm/min)	580	540	580	580
	Ap (mm)	3	3	3	3
	Ae (mm)	9	10	12	15
Tool & die steel (1.2344,1.2379) 150-255HB	N (min ⁻¹)	1,280	1,200	960	770
	Vf (mm/min)	580	540	580	580
	Ap (mm)	3	3	5	3
	Ae (mm)	9	10	12	15
Stainless steel (1.4301,1.4401) 150-250HB	N (min ⁻¹)	1,170	1,100	800	700
	Vf (mm/min)	530	500	480	530
	Ap (mm)	3	3	3	3
	Ae (mm)	9	10	12	15
Cast iron (GG25,GG30) 160-260HB	N (min ⁻¹)	1,700	1,600	1,280	1,020
	Vf (mm/min)	1,020	960	1,020	1,020
	Ap (mm)	5	5	5	5
	Ae (mm)	9	10	12	15
Nodular cast iron (GGG60,GGG70) 170-300HB	N (min ⁻¹)	1,600	1,500	1,200	960
	Vf (mm/min)	870	810	870	870
	Ap (mm)	5	5	5	5
	Ae (mm)	9	10	12	15

Note: 1. N: Spindle speed (min-1), Vf: Feed speed (mm/min)
 2. The figures to be adjusted according to the machine rigidity or work rigidity.
 3. Apply 40-60 % above depth of cut and feed rate to long type tools.

“ Side Chipper ”

■ Recommended cutting conditions for SICM_ _16 insert's type - Slotting

Materials	Parameter	ø30	ø32	ø40	ø50
Carbon steel (C50, C55) 150-280HB	N (min ⁻¹)	1,490	1,400	1,120	900
	Vf (mm/min)	670	630	680	680
	Ap (mm)	Up to 5	Up to 5	Up to 3	Up to 5
Alloy steel (1.7225) 150-280HB	N (min ⁻¹)	1,490	1,400	1,120	900
	Vf (mm/min)	540	510	540	540
	Ap (mm)	Up to 5	Up to 5	Up to 3	Up to 3
Mold steel (1.2311,P20) 280-400HB	N (min ⁻¹)	1,170	1,100	880	700
	Vf (mm/min)	430	400	430	420
	Ap (mm)	Up to 3	Up to 3	Up to 2	Up to 3
Tool & die steel (1.2344,1.2379) 150-255HB	N (min ⁻¹)	1,170	1,100	880	700
	Vf (mm/min)	430	400	430	420
	Ap (mm)	Up to 3	Up to 3	Up to 2	Up to 3
Stainless steel (1.4301,1.4401) 150-250HB	N (min ⁻¹)	1,070	1,000	800	640
	Vf (mm/min)	390	360	390	390
	Ap (mm)	Up to 3	Up to 3	Up to 2	Up to 3
Cast iron (GG25,GG30) 160-260HB	N (min ⁻¹)	1,600	1,500	1,200	960
	Vf (mm/min)	820	770	820	820
	Ap (mm)	Up to 5	Up to 5	Up to 3	Up to 5
Nodular cast iron (GGG60,GGG70) 170-300HB	N (min ⁻¹)	1,490	1,400	1,120	900
	Vf (mm/min)	670	630	680	680
	Ap (mm)	Up to 5	Up to 5	Up to 3	Up to 5

Note: 1. N: Spindle speed (min⁻¹), Vf (mm/min): Feed speed (mm/min)
 2. The figures to be adjusted according to the machine rigidity or work rigidity.
 3. Apply 40-60 % above depth of cut and feed rate to long type tools.

“ Side Chipper ”

■ Recommended cutting conditions for SICM2513 type

Materials	Parameter	Shoulder cutting	Slotting
Carbon steel (C50, C55) 150-280HB	N (min ⁻¹)	1,910	1,790
	Vf (mm/min)	860	650
	Ap (mm)	4	Up to 4
	Ae (mm)	8	–
Alloy steel (1.7225) 150-280HB	N (min ⁻¹)	1,910	1,790
	Vf (mm/min)	690	540
	Ap (mm)	4	Up to 4
	Ae (mm)	8	–
Mold steel (1.2311,P20) 280-400HB	N (min ⁻¹)	1,530	1,400
	Vf (mm/min)	560	420
	Ap (mm)	2.5	Up to 2.5
	Ae (mm)	8	–
Tool & die steel (1.2344,1.2379) 150-255HB	N (min ⁻¹)	1,530	1,400
	Vf (mm/min)	560	420
	Ap (mm)	2.5	Up to 2.5
	Ae (mm)	8	–
Stainless steel (1.4301,1.4401) 150-250HB	N (min ⁻¹)	1,400	1,280
	Vf (mm/min)	510	390
	Ap (mm)	2.5	Up to 2.5
	Ae (mm)	8	–
Cast iron (GG25,GG30) 160-260HB	N (min ⁻¹)	2,040	1,910
	Vf (mm/min)	1,040	580
	Ap (mm)	4	Up to 4
	Ae (mm)	8	–
Nodular cast iron (GGG60,GGG70) 170-300HB	N (min ⁻¹)	1,910	1,790
	Vf (mm/min)	860	650
	Ap (mm)	4	Up to 4
	Ae (mm)	8	–

- Note: 1. N: Spindle speed (min-1), Vf: Feed speed (mm/min)
 2. The figures to be adjusted according to the machine rigidity or work rigidity.
 3. Apply 40-60 % above depth of cut and feed rate to long type tools.

■ Recommended cutting conditions for SIC type

Materials	Cutting Speed Vc (m/min)	feed f (mm/tooth)	Deep Ap (mm)	Step Ae (mm)
Carbon steel (C50, C55)	150 (80 ~ 200)	0.20 (0.1 ~ 0.25)	5	0.6D
Die steel (1.2344, 1.2379)	120 (80 ~ 150)	0.15 (0.1 ~ 0.2)	3	0.6D
Cast iron (GG, GGG)	150 (80 ~ 200)	0.20 (0.1 ~ 0.25)	5	0.6D
Stainless steel (Aisi 304, Aisi 316)	110 (80 ~ 200)	0.10 (0.05 ~ 0.15)	3	0.6D

“ Side Chipper ”

■ Recommended cutting conditions for MIC and MSN zcmt 10... insert's type

Materials	Grades	Tool dia. (mm)							
		16 / 18				20 / 22			
		No. of teeth 2N				No. of teeth 3N			
		L (mm)	Ap (mm)	N (min ⁻¹)	F (mm/min)	L (mm)	Ap (mm)	N (min ⁻¹)	F (mm/min)
Carbon steel (C50, C55) Below 250HB	JC5040	70	0.6	3,580	2,150	70	0.7	2,860	1,860
		120	0.5	3,180	1,590	120	0.5	2,550	1,660
		160	0.3	2,980	1,490	190	0.2	2,390	1,550
Mold steel (1.2311, P20) 30-43HRC	JC5040	70	0.6	3,180	1,600	70	0.7	2,550	1,530
	JC5015	120	0.5	3,180	1,600	120	0.5	2,550	1,530
	JC5015 above 40HRC	160	0.3	2,980	1,490	190	0.2	2,390	1,530
Die steel (1.2344, 1.2379) Below 255HB	JC5040	70	0.6	3,180	1,600	70	0.7	2,550	1,530
		120	0.5	3,180	1,600	120	0.5	2,550	1,530
		160	0.3	2,980	1,490	190	0.2	2,390	1,530
Stainless steel Below 250HB	JC5015	70	0.6	3,180	1,600	70	0.7	2,550	1,530
		120	0.5	2,980	1,490	120	0.5	2,390	1,400
		160	0.3	2,980	1,490	190	0.2	2,390	1,400
Hardened die steel (1.2344, 1.2379) 40-50HRC	JC5015	70	0.4	1,400	350	70	0.5	1,110	420
		120	0.3	1,200	300	120	0.3	950	330
		160	—	—	—	190	—	—	—
Grey & Nodular cast iron (GG, GGG) Below 300HB	JC5015	70	0.6	2,980	1,800	70	0.7	2,400	1,680
		120	0.5	2,980	1,650	120	0.5	2,400	1,580
		160	0.3	2,500	1,380	190	0.2	2,070	1,400

L: Overhung length, Ap: Depth of cut, N: Spindle speed, F: Feed speed

NOTE

- 1) The figure to be adjusted according to the machine rigidity or work rigidity.
- 2) In case of chatter occurring, recommend to reduce the depth of cut Ap or Spindle speed and keep feed per tooth.
- 3) In case of full slotting recommend to reduce the spindle speed N and feed speed F to 70% of above figures. But do not recommend full slotting if overhung length is over 150 mm, reduce the width of cut up to 1/2D.

“ Side Chipper ”

■ Recommended cutting conditions for MIC and MSN ZPMT 13... insert's type

Materials	Grades	Tool dia. (mm)											
		22				25 / 27				40			
		No. of teeth 2N				No. of teeth 3N				No. of teeth 5N			
		L (mm)	Ap (mm)	N (min ⁻¹)	F (mm/min)	L (mm)	Ap (mm)	N (min ⁻¹)	F (mm/min)	L (mm)	Ap (mm)	N (min ⁻¹)	F (mm/min)
Carbon steel (C50, C55) Below 250HB	JC5040	70	0.7	2,600	1,300	90	1.0	2,290	1,500	100	1.5	1,430	1,070
		120	0.5	2,600	1,300	140	0.6	2,290	1,500	150	1.0	1,430	1,070
		190	0.3	2,200	1,100	210	0.3	1,900	1,230	210	0.4	1,430	860
Mold steel (1.2311, P20) 30-43HRC	JC5040	70	0.7	2,320	1,050	90	1.0	2,040	1,230	100	1.5	1,300	975
	JC5015	120	0.5	2,320	1,050	140	0.6	2,040	1,230	150	1.0	1,300	975
	JC5015 above 40HRC	190	0.3	2,200	990	210	0.3	1,900	1,140	210	0.4	1,300	780
Die steel (1.2344, 1.2379) Below 255HB	JC5040	70	0.7	2,320	1,050	90	1.0	2,040	1,230	100	1.5	1,300	975
		120	0.5	2,320	1,050	140	0.6	2,040	1,230	150	1.0	1,300	975
		190	0.3	2,200	990	210	0.3	1,900	1,140	210	0.4	1,300	780
Stainless steel Below 250HB	JC5015	70	0.7	2,320	1,050	90	1.0	2,040	1,230	100	1.5	1,300	975
		120	0.5	2,200	990	140	0.6	1,900	1,140	150	1.0	1,200	900
		190	0.3	2,200	990	210	0.3	1,900	1,140	210	0.4	1,200	720
Hardened die steel (1.2344, 1.2379) 40-50HRC	JC5015	70	0.5	1,010	255	90	0.7	890	340	100	0.8	560	330
		120	0.3	870	220	140	0.4	765	265	150	0.5	480	280
		190	–	–	–	210	–	–	–	210	0.3	480	280
Grey & Nodular cast iron (GG, GGG) Below 300HB	JC5015	70	0.7	2,200	1,320	90	1.0	1,900	1,330	100	1.5	1,200	1,050
		120	0.5	2,200	1,320	140	0.6	1,900	1,250	150	1.0	1,200	1,050
		190	0.3	1,880	1,130	210	0.3	1,600	1,040	210	0.4	1,000	900

L: Overhung length, Ap: Depth of cut, N: Spindle speed, F: Feed speed

NOTE

- 1) The figure to be adjusted according to the machine rigidity or work rigidity.
- 2) In case of chatter occurring, recommend to reduce the depth of cut Ap or Spindle speed and keep feed per tooth.
- 3) In case of full slotting recommend to reduce the spindle speed N and feed speed F to 70% of above figures. But do not recommend full slotting if overhung length is over 180 mm, reduce the width of cut up to 1/2D.

“ Side Chipper ”

■ Recommended cutting conditions for MIC and MSN ZPMT 16... insert's type

Materials	Grades	Tool dia. (mm)															
		27				32				30 / 32				40			
		No. of teeth 2N				No. of teeth 2N				No. of teeth 3N				No. of teeth 4N			
		L (mm)	Ap (mm)	N (min ⁻¹)	F (mm/min)	L (mm)	Ap (mm)	N (min ⁻¹)	F (mm/min)	L (mm)	Ap (mm)	N (min ⁻¹)	F (mm/min)	L (mm)	Ap (mm)	N (min ⁻¹)	F (mm/min)
Carbon steel (C50, C55) Below 250HB	JC5040	90	1.0	2,120	1,070	100	1.5	1,790	900	100	1.5	1,790	1,070	100	1.5	1,430	1,000
		140	0.6	2,120	1,070	150	1.0	1,790	900	150	1.0	1,790	1,070	150	1.0	1,430	1,000
		210	0.3	1,770	890	210	0.6	1,490	745	210	0.5	1,490	970	210	0.4	1,430	720
Mold steel (1.2311, P20) 30-43HRC	JC5040	90	1.0	1,890	850	100	1.5	1,600	720	100	1.5	1,600	860	100	1.5	1,300	780
	JC5015	140	0.6	1,890	850	150	1.0	1,600	720	150	1.0	1,600	860	150	1.0	1,300	780
	JC5015 above 40HRC	210	0.3	1,770	800	210	0.6	1,490	670	210	0.5	1,490	870	210	0.4	1,300	590
Die steel (1.2344, 1.2379) Below 255HB	JC5040	90	1.0	1,890	850	100	1.5	1,600	720	100	1.5	1,600	860	100	1.5	1,300	780
		140	0.6	1,890	850	150	1.0	1,600	720	150	1.0	1,600	860	150	1.0	1,300	780
		210	0.3	1,770	800	210	0.6	1,490	670	210	0.5	1,490	870	210	0.4	1,300	590
Stainless steel Below 250HB	JC5015	90	1.0	1,890	850	100	1.5	1,600	720	100	1.5	1,600	860	100	1.5	1,300	780
		140	0.6	1,770	800	150	1.0	1,490	670	150	1.0	1,490	870	150	1.0	1,200	720
		210	0.3	1,770	800	210	0.6	1,490	670	210	0.5	1,490	870	210	0.4	1,200	580
Hardened die steel (1.2344, 1.2379) 40-50HRC	JC5015	90	0.7	825	250	100	0.8	700	210	100	0.8	700	260	100	0.8	560	270
		140	0.4	710	210	150	0.5	600	180	150	0.5	600	225	150	0.5	480	230
		210	—	—	—	210	0.3	600	180	210	0.2	600	225	210	0.3	480	230
Grey & Nodular cast iron (GG, GGG) Below 300HB	JC5015	90	1.0	1,770	1,060	100	1.5	1,500	900	100	1.5	1,500	1,100	100	1.5	1,200	840
		140	0.6	1,770	1,060	150	1.0	1,500	900	150	1.0	1,500	1,100	150	1.0	1,200	840
		210	0.3	1,590	950	210	0.6	1,250	750	210	0.5	1,250	940	210	0.4	1,000	720

L: Overhung length, Ap: Depth of cut, N: Spindle speed, F: Feed speed

NOTE

- 1) The figure to be adjusted according to the machine rigidity or work rigidity.
- 2) In case of chatter occurring, recommend to reduce the depth of cut Ap or Spindle speed and keep feed per tooth.
- 3) In case of full slotting recommend to reduce the spindle speed N and feed speed F to 70% of above figures. But do not recommend full slotting if overhung length is over 180 mm, reduce the width of cut up to 1/2D.